

UPDATED DOCUMENTATION---MOuSeFET TRANSMITTERS

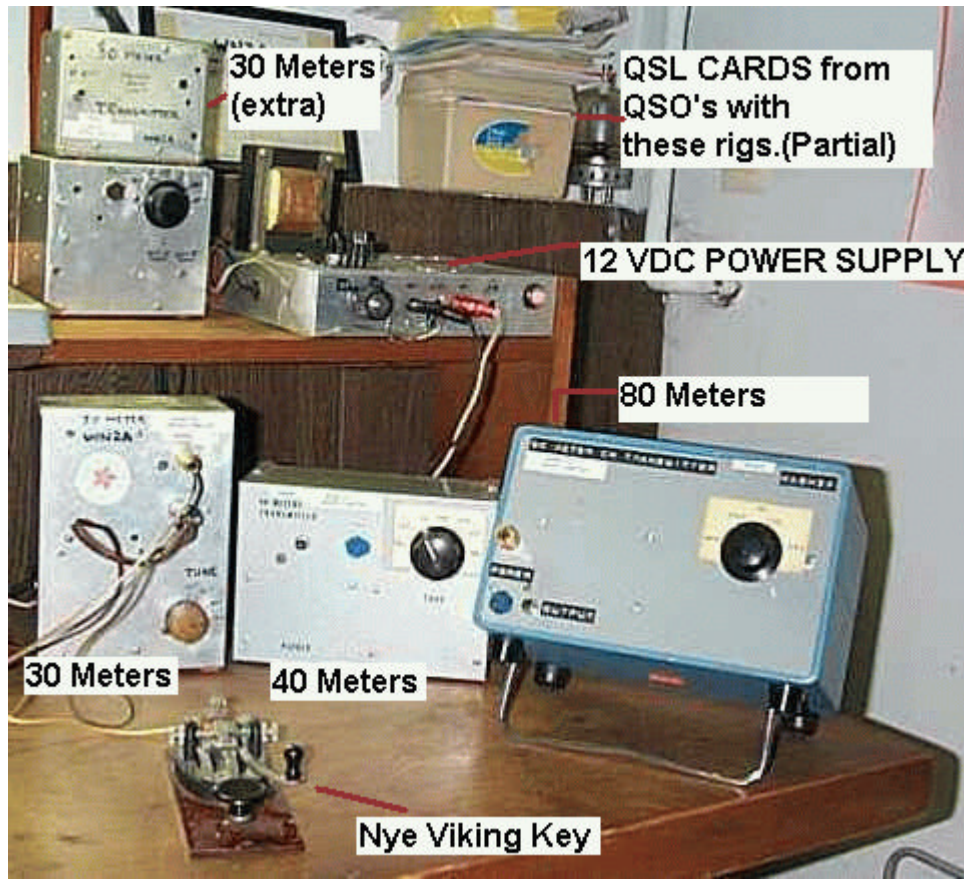

Updated information, improved circuitry and layout diagrams.

Original article was in December, 1986 QST by Mike Masterson WN2A (formerly KA2HZA).

Reprinted in QRP Classics,1990.

Winner QST Cover Plaque Award,Dec 1986

This Revision: January 2007 (Improved on 30 Meters)

QST Editor for this article was Paul Pagel, N1FB-

(whom is credited with the term MOuSeFET)

Chuck Hutchison W8CH, Technical Editor

set up the ARRL Lab tests.

These transmitters have performed extremely well over the years, with no component failures or downtime since they were built in 1985. They have been used portable on camping and vacation trips, driving a variety of antennas often with less than perfect VSWR loads. They are intended to provide a clean keyed CW signal on 80,40 or 30 meters of 12-20 watts output from +12-+13.8 VDC.

MouSeFET Update UPDATED DOCUMENTATION---MOuSeFET TRANSMITTERS

This is the revised documentation for the MOuSeFET Transmitters, originally appearing in QST, December 1986. The original circuit worked fine, with many builders writing about their success. After the original article in QST, and the reprint in "QRP CLASSICS", builders and experimenters started to write me about:

- o how easy it was to get up and running
- o how tolerant of component variations the design was
- o how much power they could squeeze out of it (one got 28 Watts with more B+ applied !)
- o their various modifications to customize it for their own use
- o the DX they were snagging with it
- o Generally great results with the A&A Engineering kits (sorry sold out !)

but also:

- o a few had problems getting power up to normal levels

It was determined that several causes could yield this result.

- o Incorrect winding polarity of T1 (accompanied by high VFO feedthru)
- o Use of "substitute" transistors that have inadequate performance for gain ,etc
- o Grounding paths too long (ex: Q5 emitter or Q6 source lead)
- o Excessive lead lengths
- o Tap location or winding errors for T2
- o Other wiring errors

The best way around these pitfalls is to get to know the RF construction practices found in:

- 1) The ARRL HANDBOOK-especially Construction Practices
- 2) Solid-State Design for the Radio Amateur,ARRL. This is a landmark text as far as QRP/Homebrew is concerned. Very useful.
- 3) QRP CLASSICS ,ARRL. Construction Practices chapter. Also numerous articles (such as mine and others) bring out some of the tips to homebrew construction.

Never Satisfied with "Good Enough"

The need for a potentiometer for balancing the original doubler stage seemed bothersome, so on recommendation of Zack, KH6CP, I tried a balanced diode doubler. This is a much easier design to duplicate and obtain a clean signal, provided one winds T1 correctly and matches D6 & D7 for forward voltage. This being done, the cancellation of VFO "feedthru" is virtually automatic. Thanks, Zack. Also, a better keying circuit developed, for better control of both keying edges. Key clicks were minimized.

Onward and Upward

Yes, there are other bands to conquer. After the 80/40 and 30 Meter versions were built, (and built..) the undersigned designed 17 and 10 meter VXO versions. The 17 Meter version delivers 10 watts out and the 10 meter yields about 7 watts. Each has its own VXO (not VFO!)

and uses the IRF510 as Q6 with +12 volts supply. 17 meter version runs about 10 watts output; 10 meter version runs about 7 watts output

- o These (and the 80/40/30 meter) units have all been in service for years with no transistor failures, even after running them into high VSWR loads.
- o The WN2A/AK2F 10 Meter Beacon is based on the 10 Meter MOuSeFET, on the air continuously since March, 1997.

I highly value the feedback from those who built the transmitters. Should you hit any snags or have any comments--drop me a line !! Also I enjoy QSO's with hams who operate homebrew QRP or low power--so let me know if you want to sked.

73's es CU on the bands Mike,WN2A. (Re-Edited for PDF file 5 May 2002 ; Revised 29 March 2003)

(Revised 11 January 2007) Deleted D5 and R4, changed to new D5 and D8 , better PA efficiency. For 30 Meters :Changed T1 Secondary From:10 Turns To: 8 Turns (Better Loading on FET Buffer, results in closer spot Frequency to TX Frequency, slightly greater power.

Legal Disclaimer: The Author assumes no responsibility or liability arising for any use, misuse or application of any information or product described herein, and makes no representations that any of the above is free from patent infringement. The author has made efforts to assure the information is correct, but assumes no liability from any errors.

REVISED (5/2002) LIST OF MATERIALS---MOuSeFET Transmitters

C11-----47uF, 16V electrolytic or tantalum
D1-D3,D5-D8----1N4148 (NOTE: D6&D7 matched for Vf approx 2mV)
D4-----8.2 V, 400mW Zener Diode (1N959 or equiv.)
FB-----2 T no. 28 enameled wire on FB-43-101 ferrite bead
J1-----9-pin Male D-type connector (Amp 747904-2 or equal)
J2-----RCA Phono Jack (Used for PA output connector)
P1-----9-pin Female D-type connector (Amp 747905-2 or equal)
Q1,Q2-----MPF-102 (2N4416 or 2N3823 alternates)
Q3-----2N3904 (2N2222, 2N2222A alternates)
Q5-----2N3053 (2N2102 ,2N1711 alternates ; D42C4 at 80 M)
Q6-----80 M : IRF523 , 40 M and 30 M: IRF510
Q7-----2N3906 or 2N2907A (general-purpose PNP silicon)
RFC1-----100 microHenry RF choke on phenolic form (Miller 4642 or equal)

Connectors J1& P1 were Amphenol '126' series replaced by the 9-pin Male D-type connectors.

Components without "Reference Designators"(i.e. R1,C4 etc.) listed below:

Capacitors 0.1 uF, 25V min, X7R or Z5U ceramic type. QTY=17

Resistors,carbon comp or film, 10% or better, 1/4 or 1/2 watt . Surface Mount can be used but keep power ratings in mind.

VALUES -----QTY
330 k ----- 1
470 ohm ----- 1
330 ohm ----- 1
1.1 k ----- 1
10 k ----- 2
39 k ----- 1
1.8 ohm ----- 1
100 ohm ----- 2
4.7 k ----- 1
2.7 k ----- 2

Capacitor Tables

TABLE 1A: FREQUENCY DEPENDENT CAPACITOR VALUES			
CAPACITOR	80 METERS	40 METERS	30 METERS
C1	25 pF air variable	35 pF air variable	35 pF air variable
C2	450 pF (9 X 50 pF N)	1000 pF (N/P)	940 pF (2 X 470 pF N/P)
C3	50 pF (N)	470 pF (N/P)	600 pF (6 X 100 pF N/P)
C4	200 pF (2 X 100 pF)	100 pF	100 pF
C5	200 pF (2 X 100 pF)	100 pF	50 pF
C6	1000 pF	470 pF	330 pF
C7	3300 pF	1000 pF	400 pF
C8	2700 pF	1410 pF (3 X 470 pF)	1000 pF (10 X 100 pF)
C9	1100 pF	700 pF (7 X 100 pF)	400 pF (4 X 100 pF)
C13	Not Used	250 pF (5 X 50 pF N)	250 pF (5 X 50 pF N)
C14	Not Used	60 pF Trimmer	60 pF Trimmer

Notes: N=NPO ceramic; P=polystyrene; N/P=NPO ceramic or polystyrene. Silver-mica capacitors can be substituted for the polystyrene types. If type is not specified above, then any of the three types will suffice.

Resistor Tables

RESISTOR	80 METERS	40 METERS	30 METERS
R2	47 OHMS	68 OHMS	68 OHMS
R3	22 OHMS	33 OHMS	33 OHMS
R4	DELETED	DELETED	DELETED

Inductor Tables

TABLE 2: FREQUENCY DEPENDENT INDUCTOR VALUES			
INDUCTOR	80 METERS	40 METERS	30 METERS
L1	14.5 uH 60t on T50-6 tap at 14 t	14.1 uH (AWG#36) 40t on 3/8 in dia ceramic form	7 uH 35t on 3/8" dia ceramic form
L2	13t on FT-37-61	9t on FT-37-61	9t on FT-37-61
L3	19t on T50-2 (1.8uH)	12t on T50-6 (0.5uH)	9t on T50-6 (0.33uH)
L4 (note1)	15t on T50-6 (0.9 uH)	10t on T50-6 (0.43 uH)	8t on T50-6 (0.3 uH)
L5 (note 1)	22t on T50-2 (2.8 uH)	15t on T50-2 (1.2 uH)	13t on T50-6 (0.9 uH)
L6	11t on FT-37-61	10t on FT-37-61	9t on FT-37-61
L7	11t on FT-37-61	9t on FT-37-61	6t on FT-37-61
T1	PRI: 18t SEC: 11t bifiliar FT50-61	PRI: 18t SEC: 11t bifiliar FT50-61	PRI: 12t SEC: 8t bifiliar FT50-61
T2 (note 2)	PRI: 40t tap at 20t SEC: 7t T50-2	PRI: 28t tap at 7t SEC: 5t T50-2	PRI: 23t tap at 9t SEC: 4t T50-2
RFC2	18 uH RF Choke	8 uH RF Choke	4 uH RF Choke

Notes: All inductors wound with #28 enameled wire except as noted.

1) L4 & L5 wound with two parallel lengths #28 enameled wire; this is done to increase the effective wire size. These are not true "bifiliar" windings.

2) Tap measured from Q7 side of primary.

3) T50-2 and T50-6 are powdered-iron toroids (Micrometals)

FT37-61 and FT50-61 are ferrite toroids. Ferroxcube 3/8 and 1/2 inch 4C4 toroids may be substituted respectively.

FIGURE 1: VFO BOARD SCHEMATIC

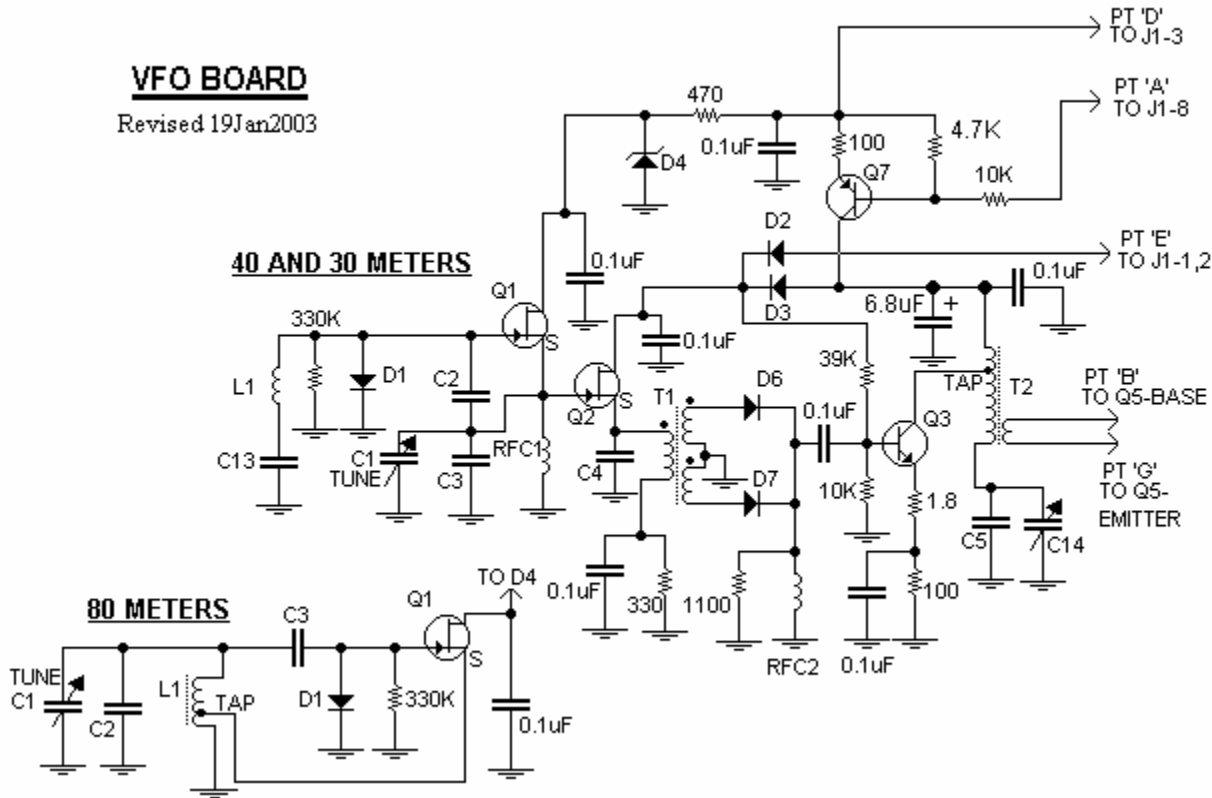

FIGURE 2: PA BOARD SCHEMATIC

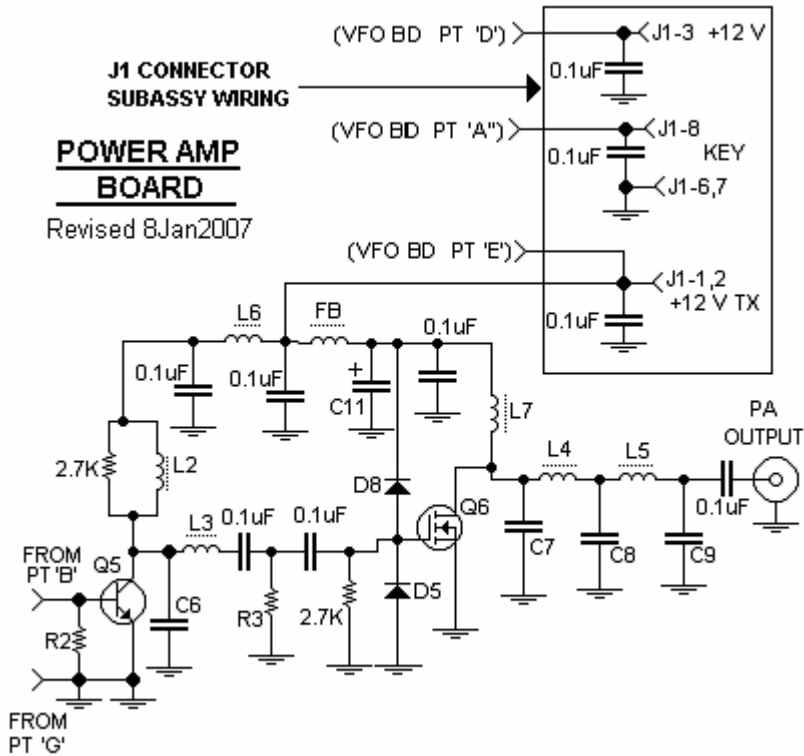

Photo of PA Board- Parts Annotated

